

# Electronic Cruise Control for Yamaha FJR1300 without ABS brakes

Model year from 2003 to 2005



The following provides a brief description of the power consumption and component locations of the MotorCycle Setup electronic cruise control.

Installed weight of the cruise control is approximately 1.8kg.

Current draw while the cruise is switched on, but not engaged, is approximately 0.250 amp (3 watts). Current draw while the cruise is engaged is nominally 0.50~0.80 amp (6~10 Watts).

By comparison, a head light bulb typically draws about 4 amps (55 Watts), and a tail light bulb (running light) draws about 0.4 amp (5 Watts).

Refer to the line drawing on the back of this sheet to identify the components from the numbers in the text.

The **Computer (1)** mounts under the rear seat.

If desired the computer may be placed flat in the bottom of the tool compartment, however this requires great care in routing the wiring loom and uses a significant amount of the available room in the tool compartment.



The **Actuator (2)** is bolted to the frame behind the right side cover. A **vacuum hose assembly (3)** is provided to connect the actuator to the engine.

The **Cable Interface Unit (4)** is located inside the left side fairing panel, behind the radiator and has a new **cable (5)** running from it to the fuel injection throttles.



The **Speed sensor (6)** is mounted on the end of the right hand side of the swing arm under the axle pinch bolt. Nickel plated magnets are placed in the heads of the bolts that mount the brake disc.

The **Control Switch (7)** is mounted to the left hand (clutch) master cylinder handlebar clamp. The bracket mounts between the bottom faces of the clamp and the master cylinder. The clamp must have about 1~1.5mm (0.040"~0.060") filed from the bottom face to allow for the thickness of the switch bracket.



If the mounting of the control switch under the handlebar limits the use of tank bags, an alternative bracket to mount the control switch above the handle bar is available.



The **Wiring Loom (8)** uses the same type of plugs that are already used on the motorcycle. Power for the cruise control and brake sensing is taken off the brake light switches by unplugging the rear brake light switch. Matching connectors on the cruise control loom are plugged in to the switch and the bike's loom. Tach (engine speed) sensing is detected from the bike's ignition coils. This is used to disengage the cruise if the clutch is operated. The cruise control is grounded on the negative battery terminal.

The wiring loom incorporates a new safety device, the 'CruiseSafe' actuator power relay. This device is a simple relay that is operated by the brake light switches. If the cruise control should malfunction, either due to electrical interference or component failure, applying the brakes enough to turn the brake light on will instantly cut power to the cruise control actuator (servo). Releasing the brakes will restore power to the actuator. This device is fail-safe in all respects except one. The brake light switches must be operative for this device to work.

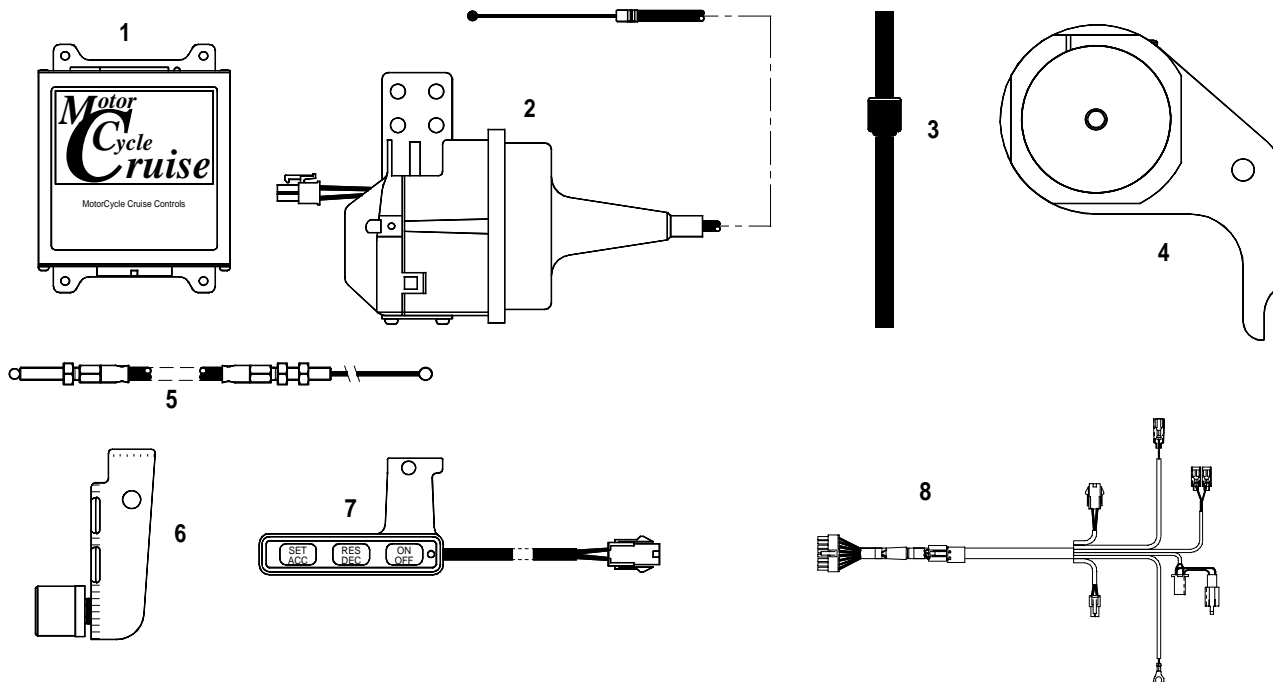

## ***MotorCycle Cruise Controls***

**6 Kingston Street  
Mount Waverley VIC 3149  
AUSTRALIA**

**Web Site:** <http://www.mccruise.com>

**International: Phone** (International Access Code) 61 3 9808 2804

**Fax** (International Access Code) 61 3 9808 2445

**Australia: Phone** (03) 9808 2804

**Fax** (03) 9808 2445

**E-mail:** [mccruise@optusnet.com.au](mailto:mccruise@optusnet.com.au)